

HORIZONTAL TOP SERIES

LED Lights enhanced product display

FEATURES

- ▶ Interior LED lights for POS attraction
- ▶ Flat tempered glass sliding lids
- ▶ White zinc coated, baked on enamel steel exterior
- ▶ Painted white powder coated steel interior
- ▶ Flat top 3-compartment baskets
- ▶ Removable rubber bumper guards / grill side
- ▶ Dual heavy-duty casters / two locking
- ▶ Molded plastic lid frame heated with reverse gas
- ▶ External analog thermometer display
- ▶ Control panel w/adj temp range +10 to -18°F
- ▶ Bottom defrost drain with plug
- ▶ Lid lock and keys
- ▶ Refrigerant CFC-free R-134a (MSF31C, MSF43C, MSF52C)
- ▶ Refrigerant CFC-free R-404a (MSF71C)
- ▶ 6-1/2 ft power cord and plug set

OPTIONS

- ▶ Custom graphics and light canopy



MSF-43C

EXTERNAL TEMP DISPLAY

CONTROL PANEL
Thermostat, Power, LED Lights

SPECIFICATIONS

Model	Baskets/ Dividers	External Dimensions W x D x H	Gross Cu Ft	Net Cu Ft	Shipping Weight	Amps	H/P	Electrical
MSF-31C	2	31.0" x 27.0" x 33.5"	7.5	6.0	159	2.0	1/3	115/120V, 60Hz
MSF-43C	3	43.0" x 27.0" x 33.5"	11.5	9.0	192	3.5	1/3	115/120V, 60Hz
MSF-52C	4	52.0" x 27.0" x 33.5"	14.0	11.5	224	3.5	1/3	115/120V, 60Hz
MSF-71C	5	71.0" x 27.0" x 33.5"	20.0	16.5	280	6.0	2/3	115/120V, 60Hz

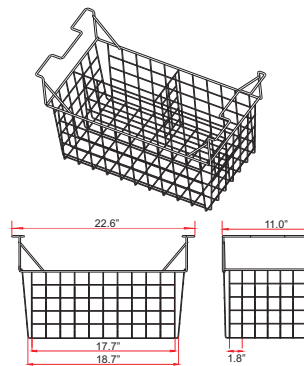
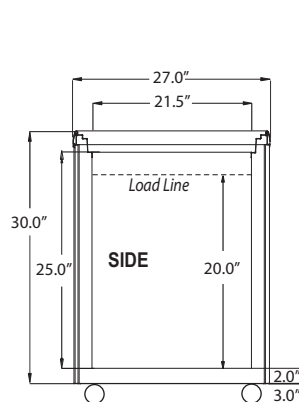
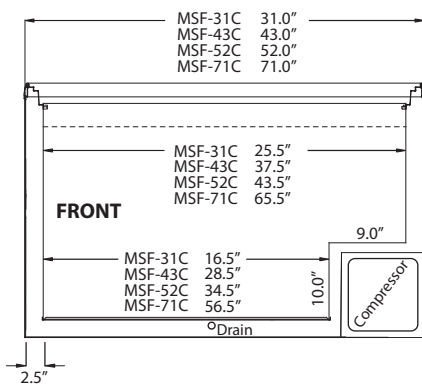

WARRANTY
18 Months Parts and Labor
5 Years Compressor (part only)
Administered by:
Metalfrío Solutions
(888) 403-0070 Toll Free

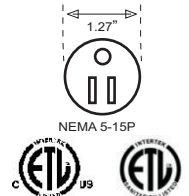

Product design and specifications are subject to modification by manufacturer without prior notice.