

# ANGLED CURVE TOP SERIES



Model MSC-41  
Angled top for enhanced product display

## FEATURES

- ▶ Anti-fog tempered curved glass sliding lids
- ▶ White powder coated, baked on enamel exterior
- ▶ Painted white powder coated aluminum interior
- ▶ New deep angled baskets with dividers
- ▶ Dual heavy-duty casters, two locking
- ▶ Adjustable thermostat, temp range +10 to -18°F
- ▶ Bottom drain with plug
- ▶ Refrigerant CFC-free R-134a - MSC-30, MSC-41, MSC-52
- ▶ Refrigerant CFC-free R-404a - MSC-70
- ▶ 6-ft power cord and plug set

## OPTIONS

- ▶ Lid lock and keys
- ▶ Hanging thermometer
- ▶ Custom graphics

## SPECIFICATIONS

| Model  | Baskets / Dividers | External Dimensions W x D x H | Gross Cu Ft | Net Cu Ft | Shipping Weight | Amps | H/P | Electrical     |
|--------|--------------------|-------------------------------|-------------|-----------|-----------------|------|-----|----------------|
| MSC-30 | 3 / 3              | 29.5" x 25.5" x 30.5/35.5"    | 7.4         | 5.3       | 155             | 3.0  | 1/4 | 115/120V, 60Hz |
| MSC-41 | 4 / 4              | 41.0" x 25.5" x 30.5/35.5"    | 11.3        | 8.3       | 183             | 4.0  | 1/3 | 115/120V, 60Hz |
| MSC-52 | 5 / 5              | 51.5" x 25.5" x 30.5/35.5"    | 14.7        | 11.0      | 210             | 5.0  | 1/3 | 115/120V, 60Hz |
| MSC-70 | 6 / 6              | 69.7" x 25.5" x 30.5/35.5"    | 21.2        | 15.7      | 272             | 6.0  | 3/8 | 115/120V, 60Hz |

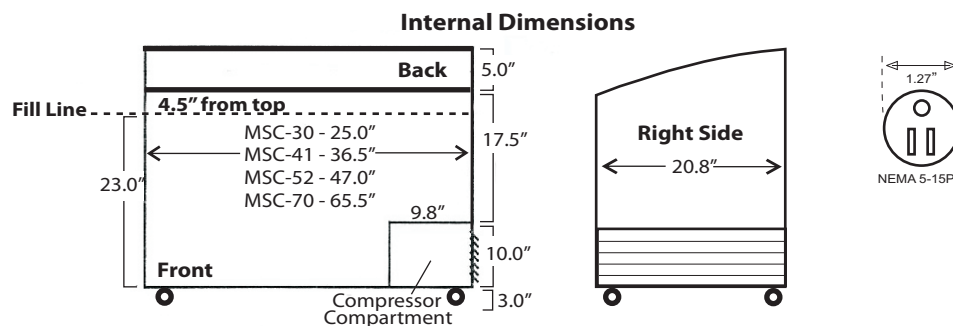

**WARRANTY**  
18 Months Parts and Labor  
5 Years Compressor (part only)  
Administered by:  
Metalfrio Solutions  
(888) 403-0070 Toll Free



Product design and specifications are subject to modification by manufacturer without prior notice.