



FIP-50



FIP-50 SERIES

Ice Cream And Novelty Display Merchandiser

Refrigeration system features low maintenance bare tube condenser coil.



MODEL

FIP-50

FEATURES

NEW STANDARD TEXTURED FINISH

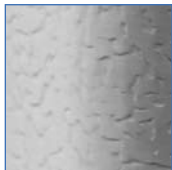

Standard white

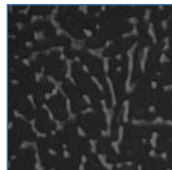

Black also available

CONSTRUCTION

- Standard electronic controller with these features:
 - Ability to monitor defrost functions from the front panel interface
 - Audible alarm
 - Eliminates room thermostat, defrost termination/fan delay control, defrost timer and digital thermometer or other temperature indicator
- 24 gauge painted textured steel interior and exterior

- 60" x 19" top stainless steel serving deck
- Extra large, non-fogging front display window
- Four panes of tempered glass with a viewing area of 11.7 sq. ft.
- Removable backlit merchandising sign in stainless steel frame
- Anodized aluminum trim with black vinyl inlay
- Four adjustable heavy-duty, white epoxy-coated, welded wire shelves
- Protective front bumper
- Full length fluorescent lamp
- Automatic condensate evaporator
- Independent on/off light switch
- 2" foamed-in-place "zero ODP" urethane insulation

DOORS

- Replaceable magnetic door gasket
- Foamed-in-place rear doors
- Self-closing

REFRIGERATION

- Self-contained, semi-hermetic condensing unit

- Rear air intake and discharge
- Automatic defrost
- Refrigerant: R-404A
- No minimum clearance required on cabinet sides but front, back and top must be left open for customer and operator access
- Temperature range: 0° to -20°F (-18° to -29°C)
- R-factor (insulation efficiency rating): 17.24

WARRANTY

- Standard limited three year extended compressor and two year limited parts and labor

OPTIONS

- Custom colors
- Casters



FIP-50 SERIES

ICE CREAM AND NOVELTY DISPLAY MERCHANDISER

TECHNICAL SPECIFICATIONS

MODEL	DIMENSIONS (in.)			DIMENSIONS (mm)			VOLTS	AMPS	UNIT H.P.	NO. OF SHELVES	STANDARD SHELF SIZE (in inches)	DISPLAY AREA SQ. FT.	CAP. CU. FT.	SHIP CU. FT.	SHIP WT. (LB/KG)
	L	D	H	L	D	H									
FIP-50	60	31	50	1524	787	1270	115	13.4	3/4	4	*	18.0	18.1	87.0	640/291

*Upper right hand and upper left hand shelves measure 12" x 27". Lower right hand and lower left hand shelves measure 15" x 27".

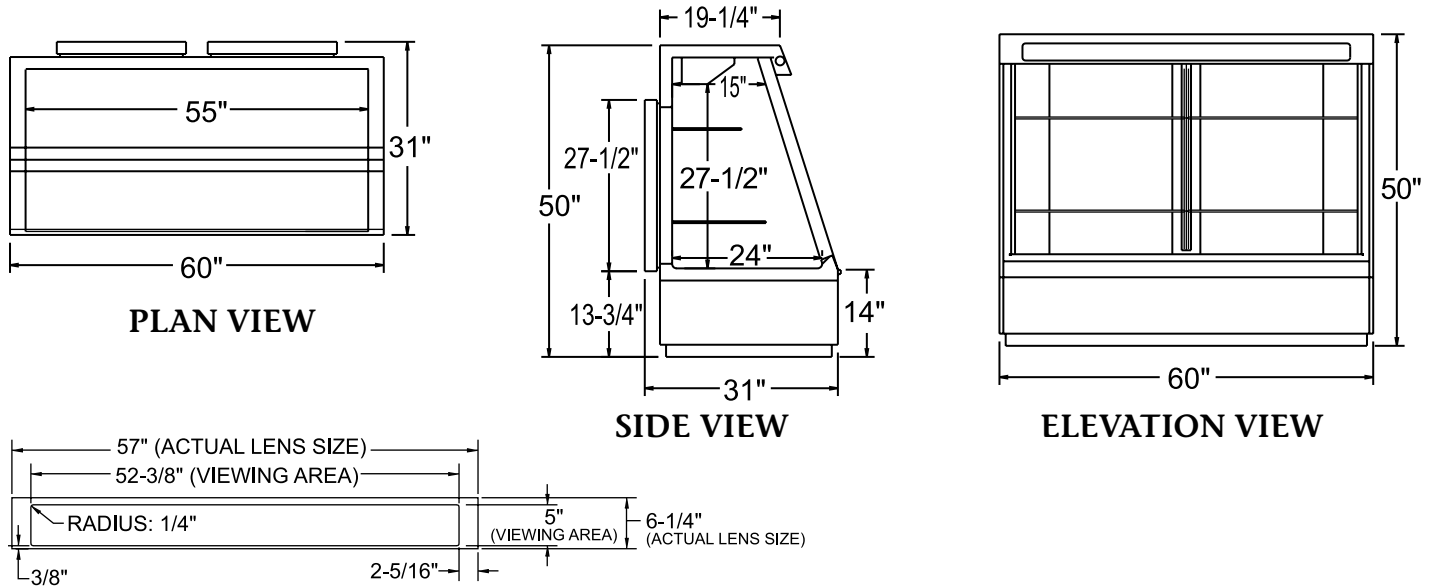

REMOVABLE LENS DIMENSIONS

LISTINGS



HOOKUP

Via plug in, 9 foot long, flexible 3 wire 14/3 cord with molded plug. Fifteen amp service is required.



BID SPECIFICATIONS

Item no. FIP-50
Provide _____ ()
Low Temp Ice Cream and Novelty Display Merchandiser(s), Master-Bilt model no. FIP-50.

Merchandiser to be provided with an electronically controlled monitoring system.

Merchandiser to feature textured finish on interior and exterior, 60" x 19" top stainless steel serving deck, extra large non-fogging front display window, four panes of tempered front glass, backlit merchandising sign

in stainless steel frame, anodized aluminum trim with black vinyl inlay, protective front bumper, four adjustable heavy-duty, white epoxy-coated welded wire shelves, and a full length fluorescent lamp.

Merchandiser to also have automatic condensate evaporator and independent on/off light switch. Cabinet to be foamed-in-place with "zero ODP" urethane insulation and to have a sparkling white polyester enamel interior and exterior. The doors are to be

self-closing and have magnetic door gaskets. Rear doors are to be foamed-in-place.

The refrigeration system is to have a self-contained, semi-hermetic condensing unit using R-404A refrigerant. Refrigeration system will also contain a low maintenance bare tube condenser coil. The temperature range is to be 0° to -20°F (-18° to -29°C).

Merchandiser to have standard limited three year extended compressor warranty and two year limited parts and labor warranty. Merchandiser to be UL, C-UL & NSF listed.

NOTE: Cabinet designed for optimum performance in air-conditioned area at 75°F ambient and 55% relative humidity. All specifications subject to change without notice.



908 Highway 15 North • New Albany, MS 38652
PHONE: 800-647-1284 or 662-534-9061 • FAX: 800-232-3966 or 662-534-6049 • www.master-bilt.com

