

FROZEN NOVELTY PUSHCARTS

Enjoy or sell ice cream novelties and pre-packaged frozen desserts ANYTIME, ANYWHERE!

Specifications

Lid locks standard on all models.
 Top to be 18 ga. type 304 stainless.
 Base frame to be welded aluminum.
 All exposed corners welded and polished smooth.
 Finished exterior to be white Lexan, standard.
 Wheels to be 6" or 8" diameter
 2) swivel w/locks, (2) rigid.
 Load rating of wheel to min of 350 lbs ea.
 Interior of cart to be 24 ga. stainless.
 Bottom drain for defrost.
 Condensing unit on glide-out base with service valves.
 Carts to have 5 yr. ltd warranty for coldplate failure, insulation failure or internal tubing leaks.
 NSF & UL listed for outdoor use.
 Options available include;
 custom artwork panels, umbrella, overhead awnings, fold-down shelf, bicycle wheels, and more

Model BDC8 (Shown above w/custom graphics)
 Capacity 9 cu.ft.,
 Approx 800 Novelties,
 Cold Plates Standard,
 1/3 h.p. compressor, 8 amps, 115 volts
 R404a refrigerant

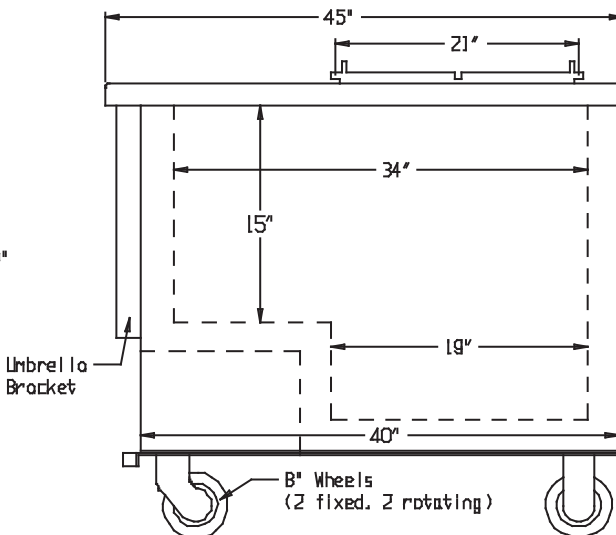
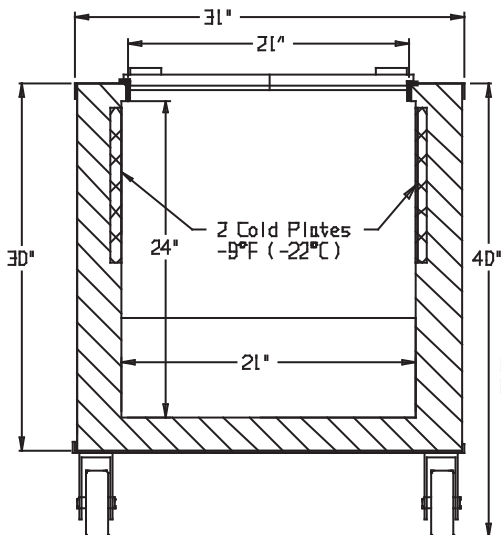

Model BDC8