



BEVERAGE-AIR

PO Box 5932, Spartanburg, SC 29304
1-888-845-9800 Fax# 1-864-582-5083
<http://www.Beverage-Air.com>

Commercial Refrigeration Equipment General Specification

MS SERIES—MIX & BULK MILK STORAGE

Available in 58" and 68" width. Units are ideal for storing mix and bulk milk.

CABINET CONSTRUCTION

Standard, cabinet exterior is constructed of heavy-duty white coated steel. Stainless exterior options available. Equipped with 2" stainless steel top. Doors are self-closing and include key locks. Magnetic door gaskets provide positive door sealing. Doors are field reversible with hinge kit accessory.

Standard interior construction utilizes galvanized steel walls and ceiling. Reinforced floor and doorsills are made from heavy-duty stainless steel to provide long lasting service.

Interior, incandescent, lighting is standard with manual on/off switch.

Foamed-in-place CFC and HCFC-free polyurethane insulation enhances the structural strength of the cabinet and helps increase energy efficiency.

REFRIGERATION

Lift-out refrigeration system uses R134a refrigerant, which is CFC and HCFC-free for compliance with environmental safety concerns.

Condensate elimination is automatic and non-electric.

ELECTRICAL

Units wired at factory and ready for connection to a 115/60/1 phase, 15 amp dedicated outlet. 8' long cord and plug set included.

SPECIAL FEATURES

- Three sizes of syrup rails available (optional)
 - 3 jar rail: 15 5/8" W x 8 3/8" D x 10 19/32" H
 - 6 jar rail: 29 13/32" W x 8 3/8" D x 10 19/32" H
 - 9 jar rail: 43 3/16" W x 8 3/8" D x 10 19/32" H
- Six fruit jar inserts available (optional)

Item No. _____
Quantity _____

MIX & BULK MILK STORAGE MS SERIES

MODELS:
MS58
MS68



MS58 (white exterior shown)



MS68 (white exterior shown)

ELECTRICAL CONNECTION



115/60/1
NEMA-5-15P

Units pre-wired at factory and include 8' long cord and plug set.



*Note: Not all markings may apply to all model variations.

Available From:

Model Specified _____	Store# _____
Location _____	Quantity _____



BEVERAGE-AIR

Mix & Bulk Milk Storage
Models: MS58, MS68

MODEL	MS58	MS68
EXTERNAL DIMENSIONAL DATA		
Length Overall (inches)	59"	69"
Length Overall (mm)	1499	1753
Depth Overall (inches)	28 3/16"	28 3/16"
Depth Overall (mm)	716	716
Height Overall— (inches)	37 1/4"	37 1/4"
Height Overall—(mm)	946	946
Clear Door Width (inches)	21" x 29 15/16"	21" x 29 15/16"
Depth With Door Open 90°	50 1/2"	50 1/2"
Number of doors	2	2
INTERNAL DIMENSIONAL DATA		
NET Capacity (cubic ft.)	23.8	28.4
NET Capacity (Liters)	674	804
Internal Length Overall (inches)	55"	65"
Internal Length Overall (mm)	1397	1651
Internal Depth Overall (inches)	23"	23"
Internal Depth Overall (mm)	584	584
Internal Height Overall (inches)	32"	32"
Internal Height Overall (mm)	813	813
Number of Shelves	4	4
ELECTRICAL DATA		
Full Load Amperes 115/60/1	7.2	7.2
ENERGY CONSUMPTION (KWH)		
	4.37	3.55
REFRIGERATION DATA		
Horsepower	1/3	1/3
WEIGHT DATA		
Gross Weight (Crated lbs)	360	390
Gross Weight (Crated kg)	163	177

PLAN VIEWS

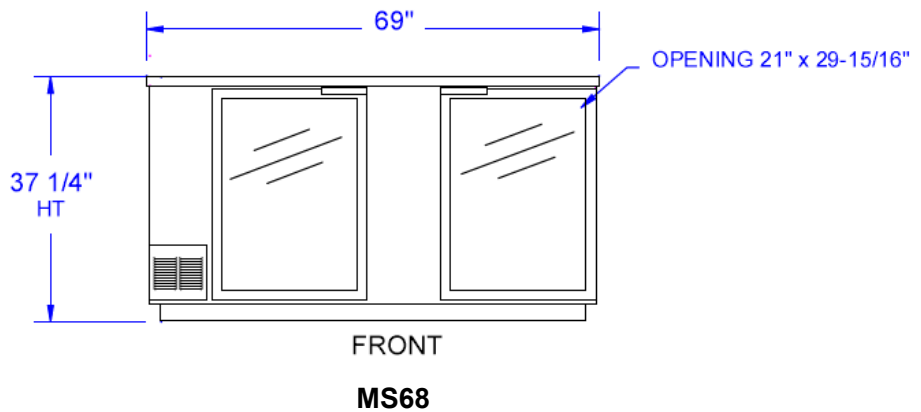
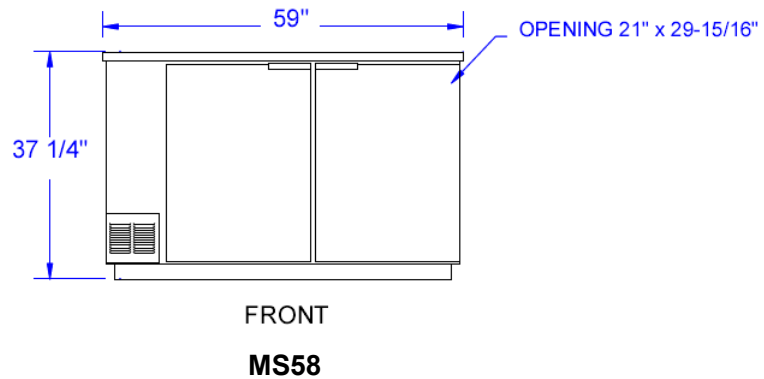
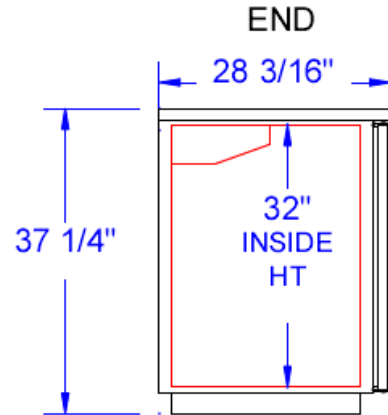

*Note: Not all markings may apply to all model variations.

ELECTRICAL CONNECTION

Units pre-wired at factory and include 8' long cord and plug set.



BEVERAGE-AIR® CORPORATION

700 Buffington Road • PO Box 5932 • Spartanburg, SC 29304 USA • (864) 582-8111 • Fax (864) 582-5083 • (888) 845-9800 • www.beverage-air.com

Specifications are subject to change without prior notice. 01/10